



The **ELITE** Truck Protection Plan For Vocational Vehicles

The Most Comprehensive Equipment Coverage Plan You Can Buy.

Vocational trucks are built to perform special tasks. So its important to protect the critical equipment on those trucks like engine, aftertreatment, fuel injectors, and turbos so when the truck is needed, it's ready to perform. That's why Premium 2000+®, the #1 truck protection brand in the industry, is introducing the **ELITE** Truck Protection Plan designed specifically for vocational vehicles.

Its a reality that used commercial trucks will have mechanical failure as they age, and those repairs can cost you thousands of your hard earned dollars. The **ELITE** program will pay for repairs on components covered by the plan you purchased. In fact, we pay tens of millions of dollars in claims every year to keep our customers on the road. Now that's a little peace of mind you can count on.

ELITE Equipment Coverage Benefits

- **Equipment Coverage Options:**
 - Engine, Aftertreatment, Critical Components (Fuel Injectors, Water Pump, Turbos, and more), Transmission, HVAC, Starter, Alternator, Radiator, and more.
- **Generous Limits of Liability:**
 - Engine: \$22,500
 - Aftertreatment: \$12,000 (one box); \$8,000 other
 - Trans & Rears: \$7,500
 - Turbo(s): \$7,500
- **Expanded Covered Conditions for Progressive Damage and Wearout**
- **Rapid Repair Guarantee™** included in **ELITE** Truck Protection Plan
- **FREE Towing** (see contract for details)
- **Rear Apparatus Vehicles**
Rear apparatus is not covered by this program. Specific programs are available for custom body applications like boom, digger, refuse, and other.

* See coverage details on back



YOUR TRUCK IS YOUR LIVELIHOOD

A Premium 2000+ **ELITE** Truck Protection Plan is an investment in your business that gives you:

- 1 Peace of mind**
Rest easy knowing you're covered if something goes wrong with the equipment covered by your plan.
- 2 Financial protection**
Protect against expensive mechanical issues that can derail your business.
- 3 Essential coverage**
Protect the most important parts of your truck, like the engine, turbo(s), transmission, aftertreatment and more.
- 4 Exceptional customer service**
We make it our business to take care of your business when you need us. You can reach us through your own personal online portal, email or phone.
- 5 Impressive payouts**
It's simple. If your failure is covered by the plan you purchased, we'll pay for the repair.

High Risk of Equipment Failure After Factory Warranty Ends

Cost of Repairs for Claims Paid (Over the life of the program)

Example of Basic Warranty Coverage for New Heavy Duty Trucks

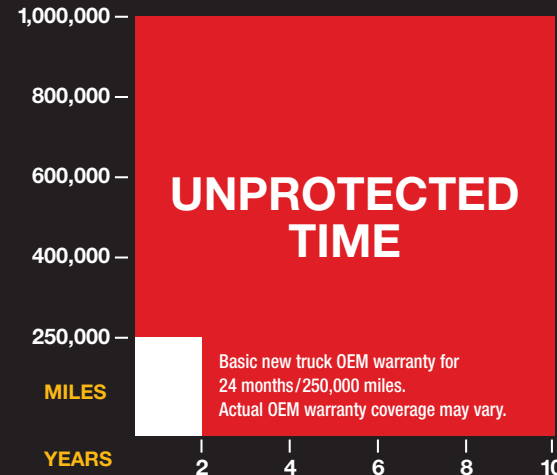

- 64% of paid claims have repair costs over \$5,000
- Nearly 1 in 4 claims had repair costs over \$10,000



Since 1995, our mission has been to keep you and your truck on the road and moving. That's why we are always designing the industry's best truck protection plans to protect your most important asset. And when you need us, we'll be there to provide outstanding customer service to get you back on the road as quickly and safely as possible.

For more information on a Premium 2000+ Truck Protection Plan that best fits your business, contact your local used truck dealer or email us at contactus@ntpco.com.

Major Components Repair Costs Range

The high cost to repair one major equipment failure could put your business in jeopardy. A Premium 2000+ Truck Protection Plan will protect your business, your investment and your livelihood.

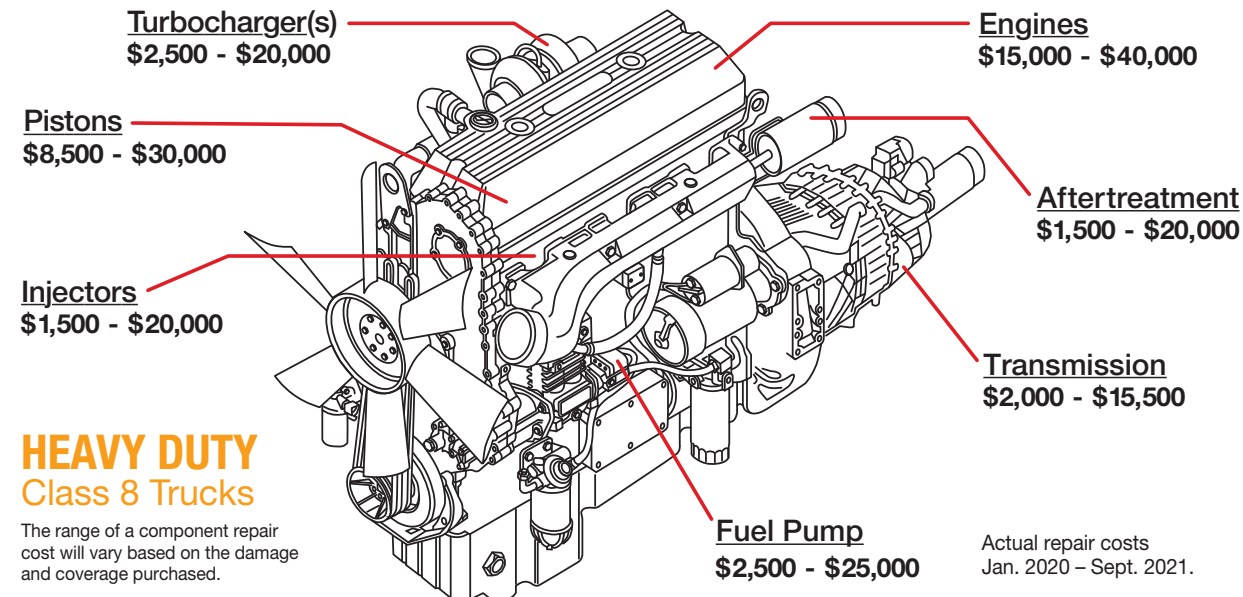

877-950-3200

premium2000.com

claims@ntpco.com

7990 North Point Blvd
Suite 100
Winston Salem, NC 27106

Premium 2000+ *ELITE* Truck Protection Plan for Vocational Vehicles

Please refer to your signed vehicle service contract for complete coverage language and Limits of Liability. The Total Aggregate Limits of Liability for all covered claims shall not exceed \$30,000, or the retail value of the vehicle, whichever is less.

RAPID REPAIR GUARANTEE PLUS

INCLUDED WITH EXTENDED PLAN

No other Truck Protection Plan offers a guarantee on getting you in and out of the repair facility and back on the road safely.

This program guarantees that after the claim approval is complete, our National Repair Network will have you on the road within 14 days, or we will pay you, or the lien holder, half of your monthly truck payment, up to \$750. If repairs require more than 30 days from the time the claim is approved, we will pay you, or the lien holder, your total monthly truck payment, up to \$1,500.

This only applies to repairs performed under the Premium 2000+ contract and an OEM authorized repair would not be covered by it.

ADDITIONAL COVERAGES AVAILABLE:

- **Comfort Package**
- **Transmission and Differential**

Comfort Package™ (LOL \$6,000) OPTIONAL

- Alternator
- Charge Air Cooler
- Engine Air Compressor
- Engine Brake
- Fan Clutch
- Fan Hub
- Fuel Tanks, Cap, & Valve
- HVAC Air Compressor & Pulley
- HVAC Blower Motor & Resistor
- HVAC Heater Core
- HVAC Temperature Controls, Control Head, & Control Valves
- Radiator & Radiator Cap
- Radio
- Starter & Starter Solenoid

Eligibility

- Class 8 model year up to 10 years including the current calendar year.
- Start miles <400K miles; program expires at 550K total miles.
- Start engine hours <20,000; program expires at 25,000 engine hours.
- Rear apparatus is not covered by this program. Specific programs are available for custom body applications like boom, digger, refuse, and rear apparatus.

Underwriting

- New engine oil and filter required
- Repair identified deficiencies to maintain ROs of related underwriting repairs
- Road test/performance evaluation to identify performance & operational issues
- Visual inspection of warranted components: identify leaks at seals, gaskets, and housing; verify engine performance (i.e. skips, misses, knocking, etc.)
- Check fault codes & perform preventative maintenance
- Wrap coverage begins at expiration of prior OEM coverage (by age or mileage)

Covered Components

CC = Critical Components
LOL = Limits of Liability

Coverage Exclusions: Please refer to the Premium 2000+ vehicle service contract for complete list and details of covered and non-covered items. All costs are in US dollars.

Engine (LOL \$22,500)

Engine's internally lubricated hard parts include:

- Camshaft and Cam Bearings
- Cam Followers
- Connecting Rods
- Connecting Rod Bearings
- Connecting Rod Caps and Screws
- Crankshaft
- Cylinder Block Casting
- Cylinder Head and Head Gasket
- Cylinder Liners
- Cylinder Head Bolts
- Hydraulic Lifters
- Injector Cups
- Intake and Exhaust Valves
- Intake and Exhaust Valve Guides
- Main Bearings
- Oil Cooler and Housing
- Oil Pan
- Oil Pump Pick Up Screen and Tube*
- Oil Pump Pressure Relief Springs and Valves
- Pistons, Piston Rings and Piston Oil Cooling Jets
- Pushrods
- Rocker Arms and Rocker Arm Shafts
- Thrust Washers
- Timing Gears
- Timing Gear Cover and Housing
- Valve Cover
- Valve Retainers and Keepers (Locks)
- Valve Seats and Valve Springs
- Wrist Pins

“Non-oil” related components:

- Exhaust Manifold
- Flywheel Housing
- Intake Manifold
- Thermostat Housing
- Vibration Dampener

(CC) Engine Fuel Injectors, Water Pump, Fuel Pump & ECM (LOL \$5,000)

- Complete Injector
- Fuel Injector Hard Lines
- Fuel Injection Pump
- Fuel Pump
- Engine Control Module (ECM)
- Water Pump

(CC) Turbo(s) (LOL \$7,500)

Turbochargers include:

- Bearings
- Internal Variable Vane Assembly
- Turbine and Turbine Shaft
- Turbo Actuator

Transmission (LOL \$7,500) OPTIONAL

Internally lubricated hard parts of the manual or automatic transmission include:

- Bands
- Bearings
- Blockers
- Bushings
- Control Module (TCM)
- Drums
- Gear Sets
- Governor
- Oil Pump
- Shaft(s)
- Speed Sensor
- Shift Forks
- Synchronizers
- Thrust Washers
- Torque Converter
- Valve Body

Differential (LOL \$7,500) OPTIONAL

Internally lubricated hard parts include:

- Axle Housing
- Axle Shafts
- Bearings
- Bushings
- Carrier Case
- Gear Sets
- Limited Slip Clutch Pack

Power divider includes:

- Bearings
- Gears
- Shafts
- Shift Forks

Progressive Damage

If the Primary Failure of a covered component causes a Secondary Failure to a Non-Covered Component, we will cover repairs of the Primary Failure and Secondary Failure, collectively, up to the Primary Failure's limits of liability. Refer to contract for full details.

Wearout & Carbon Packing

Please refer to your contract for details on Wearout and Carbon Packing coverage.

Aftertreatment (LOL \$8,000; One Box \$12,000)

- Aftertreatment Electronic Control Module (ACM)
- Back Pressure Control Valve (BPV)
- Diesel Exhaust Fluid (DEF) Module with Injection Nozzle
- DEF Heater Control Relay
- DEF Dosing Module - Wiring Harness
- DEF Heated Lines (3)
- DEF Heater Coolant Control Valve
- DEF Heating Elements
- DEF Heating Fittings (3 on Supply Module)
- DEF Pump and Module
- DEF Solution Level/Temperature Sensor
- DEF Tank
- Diesel Oxidation Catalyst (DOC)
- Diesel Particulate Filter (DPF)
- DPF Air, Fuel, and Coolant Lines
- DPF Air, Fuel, Manifold Assembly
- DPF Dosing Module
- Exhaust Gas Recirculation (EGR) Valves
- EGR Actuator
- EGR Connecting Bellows and Clamps
- EGR Cooler(s)
- Exhaust Piping, Clamps, and Gaskets
- Exhaust Throttle Valve
- Hydrocarbon Doser Injector (HC Doser, 7th Injector, ARD, AHI Module)
- Hydrocarbon Doser Valve - Air, Fuel, and Coolant Lines; and Inline Air Filter
- Hydrocarbon Doser Valve (Voss Valve)
- Selective Catalytic Reduction (SCR) Catalyst
- SCR Decomposition Pipe and Pipe Elbows
- Sensor, BPV Pressure
- Sensor, Delta P (DPF Pressure)
- Sensor, DOC Inlet Pressure
- Sensor, DOC (Post) Temperature
- Sensor, DOC (Pre) Temperature
- Sensor, DPF Air Supply Pressure
- Sensor, DPF Back Pressure
- Sensor, DPF Fuel Pressure
- Sensor, Lambda (O₂ Sensor)
- Sensor, NOx (2)
- Sensor, Pressure After Exhaust Throttle Valve
- Sensor, SCR (Post) Temperature
- Sensor, SCR (Pre) Temperature
- Wiring Harness - Emission Systems (including overlay)

**PREMIUM
2000+**

ELITE TRUCK PROTECTION PLAN VOCATIONAL VEHICLES



* For Detroit Diesels, breakdowns originating from the "oil pump pick up tube O-ring" will only be covered if the TSB D18M3 has been performed by a certified OEM repair shop.